

## Gas, Electricity and Water Metering Systems



### **A UNIQUE APPROACH FOR AUTOMATIC METER READING & CUSTOMER PROFILE ANALYSIS**

Combine the most advanced OCR and low-power radio technologies to reduce your operating costs and provide value-added services to your customers

#### **Simple to install**

- Clip or glue the unit to your existing meter and the installation is over.
- No need to remove or open the meter
- No wiring necessary.
- No need for sophisticated programming on site.
- Quickly removed and re-installed on other meters.
- Integrate the unit in a Home Networking System



#### **The information you truly need**

- The unit reads the whole register value at regular intervals or on demand. Just what you need for billing purposes. No more disputes with customers.
- Log load profiles to track consumption behaviour. Ideal to improve customer service.
- The information is never lost as the unit always reads the whole register value.

#### **The maintenance you have always dreamt of**

- Install and forget the unit for 10 years, thanks to our low power technology. (Only a few  $\mu\text{A}$  of average current consumption)
- Mount the unit during the reconditioning process of your meters and save on installation costs.

### **OUR UNIQUE TECHNOLOGY**

To satisfy the most stringent requirements of Automatic Meter Reading (AMR) and customer profile analysis, Xemtec's technical approach for Optical Character Recognition (OCR) is to shift the low-level processing of the characters (in this case the numbers printed on the cyclo-registers) into the sensor itself, thus realizing a 'silicon retina'.

Indeed, unlike the classical software approach based on image transcriptions from CCD or CMOS imagers and subsequent processing by powerful microprocessors, our approach greatly reduces the system cost and power consumption, while maintaining high reliability, robustness and fast processing.

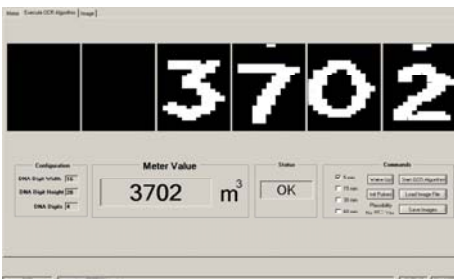

*Data output of Xemtec Opto-ASIC (edge map) and final OCR result from the post-processor in the Meter Value box*

## BLOCK DIAGRAM OF OPTO/RF END POINT

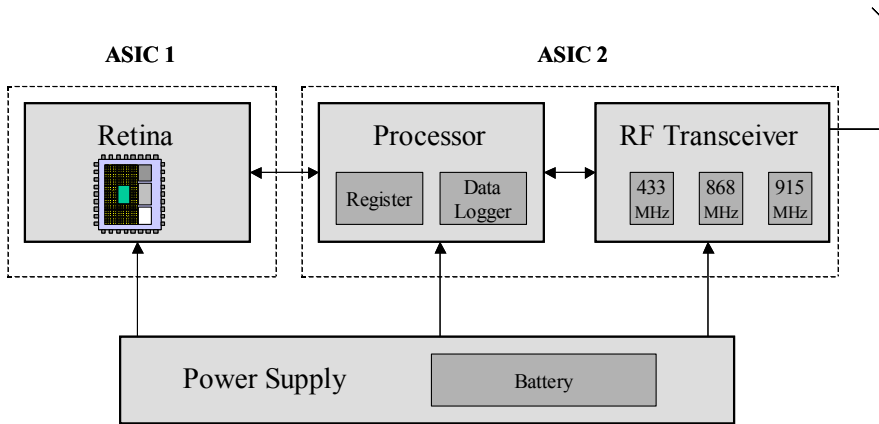

## MAIN FEATURES OF THE OPTO/RF END POINT

### Functional features

- Two-way peer-to-peer communications
- Single register / data logger capabilities
- Repeater functionality
- Real time clock
- Fraud detection
- Power-save modes

### Retina

- Matrix arrangement: 250 x 50
- SPI/I2C interfaces

### Processor

- RISC architecture
- 8k x 22-bit instruction memory, 512-byte RAM
- Mask ROM or MTP versions
- SPI, 10/O ports

### RF Transceiver

- Multi-frequency\*: 434 MHz, 868 MHz, 915 MHz
- RX sensitivity -113dBm,
- TX output power +15 bBm
- Baudrate\* 4.8k, 9.6k, 19.2k, 38.4k, 76.8k
- Digitally programmable (\*)/controlled, no tunable external components

## Xemtec System Architecture The Big Picture

